

TANNOY

KINGDOM

ROYAL

Manual

CONTENTS

4	Tannoy - A short history	34	Amplifier connections
8	Introduction to the Kingdom Royal	36	Single wire connections
10	Tannoy Dual Concentric™ drive unit	40	Bi-wiring theory
14	Supertweeter™	42	Bi-wiring connections
16	Bass driver	44	Bi-amping
18	Crossover	46	Grille removal
22	Enclosure	48	Loudspeaker system adjustment
24	Unpacking instructions	50	Running in
28	Positioning	52	Note on auditory perception
30	Amplifier choice	54	Care of cabinet
32	Cable choice	56	Fault finding
		58	Warranty
		60	Specification

TANNOY - A SHORT HISTORY

In the early days of broadcasting, radio sets needed both low and high voltage DC power that had to be supplied by batteries. The lead acid batteries used in the radio sets of the time needed regular recharging.

In London, in 1926, Guy R. Fountain perfected a new type of electrical rectifier with the aim of designing a charger more suitable for use in the house. His rectifier consisted of two dissimilar metals held in a special electrolyte solution. One metal was Tantalum and the other an alloy of Lead. So successful was this invention that Guy Fountain founded a British Company called Tannoy (a contraction of the words 'Tantalum' and 'Alloy'). Tannoy soon became internationally known and highly regarded in all

aspects of sound reproduction. Moving coil loudspeakers with DC energised magnets began Tannoy's continued success in the field of loudspeaker technology. A discrete two-way loudspeaker system followed in 1933 and shortly after a range of microphones and loudspeakers capable of high power handling.

Tannoy has always been at the forefront of the communications revolution, developing its own equipment and production technology. The company built a fund of knowledge and experience that has proved invaluable in the development of loudspeakers for a truly wide range of applications. The now famous Tannoy Dual Concentric™ principle was created and developed under Guy Fountain's direction around 1950. It is highly regarded by music enthusiasts, and recording and broadcast studios because of its unique properties in faithfully reproducing sound to a very high quality standard.





Guy Fountain retired from the company in 1974, but the Tannoy company continues his philosophy dedicated to the accurate and realistic reproduction of music for both enthusiasts and professionals around the world.

The Tannoy Research and Development unit has further refined the innovative Dual Concentric™ principle. Using the latest design and material technologies, with sophisticated circuit techniques in crossover design, Tannoy has produced a loudspeaker system with superb reproductive capabilities and exceptionally wide dynamic range.

Tannoy is now part of the TC Group, whose goal is to design, produce and distribute the best engineered, most recognised and respected brands of high performance audio products in the world.

INTRODUCTION TO THE KINGDOM ROYAL

The Kingdom Royal is a statement in engineering excellence, hand crafted to exacting standards and setting a new reference for musical performance. Distilling 80 years of Tannoy expertise into a new flagship loudspeaker of unrivalled accuracy, musical coherence and dynamic range.

Four years of extensive research, cutting edge technologies, new processes, and extensive design detailing have resulted in the most revealing and musically articulate loudspeaker Tannoy has ever built.

TANVOY

KINGDOM
ROYAL

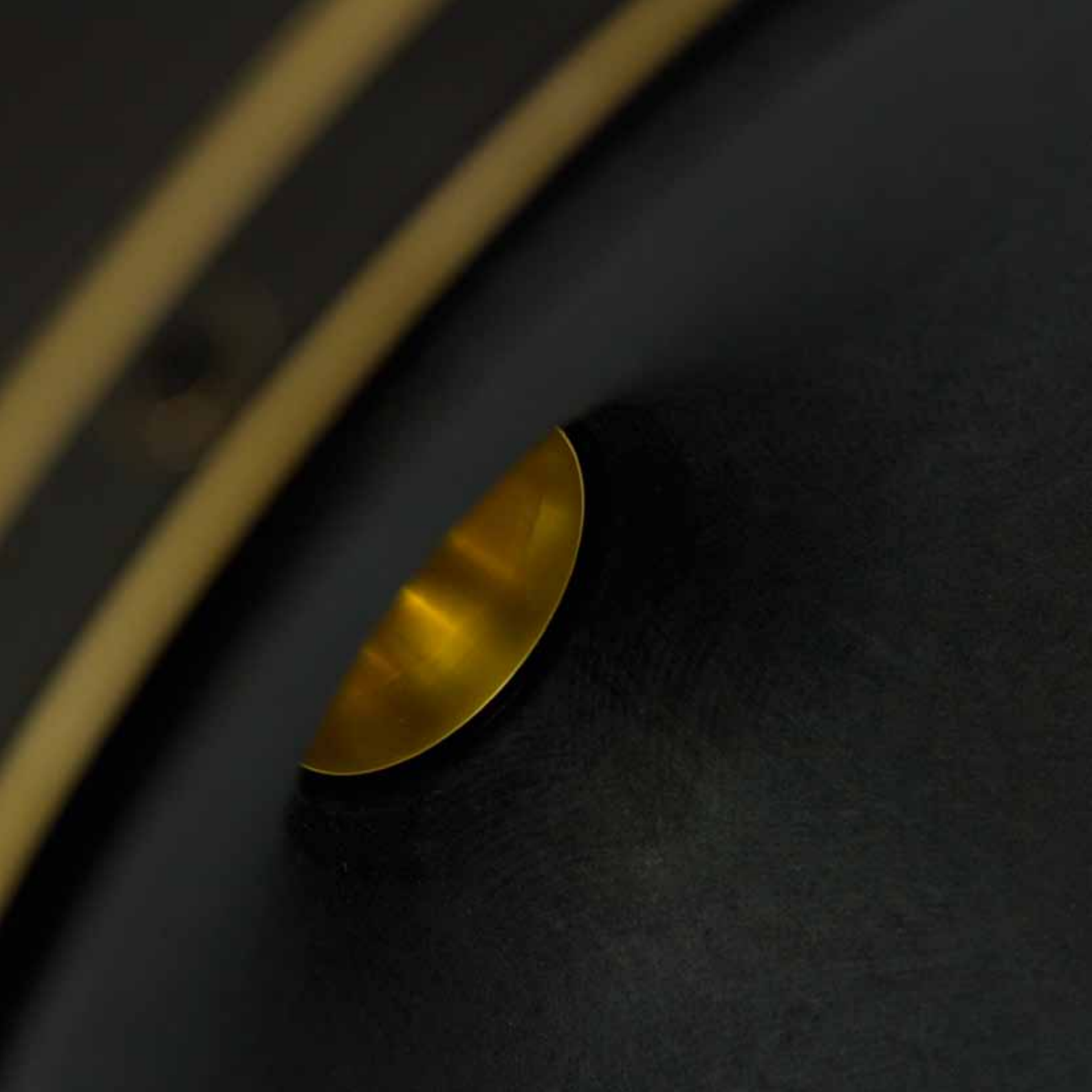

TANNOY DUAL CONCENTRIC™ DRIVE UNIT

One of the unique advantages of the Tannoy Dual Concentric™ principle is that the low and high frequency sound radiation is generated on the same axis. The high frequency unit is mounted behind, and concentrically with, the low frequency unit. High frequency sound radiates from the centre of the low frequency unit through a carefully designed high frequency exponential horn. Low and high frequencies are therefore fully integrated at source. It is this feature that gives the Dual Concentric™ driver such unique sound reproduction qualities.

There are other significant benefits. The high frequency unit does not obstruct the low frequency unit in any way (a unique feature when compared with other so called coaxial systems). Polar dispersion of sound is symmetrical in both horizontal and vertical planes.

By careful crossover network design the virtual acoustic sources of the high and low frequency units can be made to occupy the same point on the axis. Therefore the total sound appears to emanate from a single point source located slightly behind the drive unit. This means that a full and accurate stereo image can be recreated by the loudspeakers when fed from a high quality stereo source.

The Kingdom Royal has an all-new state of the art 12 inch Dual Concentric™ driver. The outer bass/ midrange driver combines a revolutionary low mass, ultra-rigid multi-fibre cone and precision edge-wound voice coil with a massive ferrite motor system for breathtaking transient response across the upper bass to lower midrange spectrum.

Its hard-edge roll surround has a very low memory effect further improving articulation in the mid and upper bass and is also damped and shaped correctly to terminate the moving cone and provide optimum compliance and linearity at large excursions. This outer driver crosses over to the high frequency unit at an exceptionally low 700Hz to ensure key vocal ranges are handled by the new tweeter.

This HF drive unit is one of Tannoy's most radical driver designs to date. It couples a 3 inch heat treated aluminium alloy dome with a 1.5kg ferrite motor to create an extremely efficient horn-loaded compression driver, to give reference standard tonal

accuracy combined with exceptional dynamic abilities. After bonding to the copper-clad aluminium voice coil, the assemblies are deep cryogenically treated. This relieves residual stresses in the microstructure of the dome and reduces crystal boundary imperfections in the voice coil for greater naturalness and emotional communication of the music.





SUPERTWEETER™

At 17kHz the Dual Concentric™ HF unit crosses over to the latest evolution Tannoy SuperTweeter™. Again many engineering hours were spent selecting the right material for the Kingdom Royal SuperTweeter™ dome, with a magnesium alloy finally being chosen for its lack of colouration, coherence and even extension out to 61kHz. Each dome is vapour coated with a thin ceramic layer for optimum rigidity and damping, before being carefully plasma treated by hand and bonded to the voice coil. This revolutionary plasma technique increases the surface energy of the dome to give greater coupling to the voice coil and ensure greater consistency. Combined with a neodymium motor and rear damping cavity, the new SuperTweeter™ offers outstanding linearity and accuracy, alongside higher sensitivity and wider bandwidth than the previous generation titanium SuperTweeter™.

For ultimate fidelity the enthusiast will appreciate the slight improvement in clarity and detail that is achieved by removing the SuperTweeter™ grilles during listening.

The Supertweeter™ grille is a friction fit part which locks onto the gold trim via four discrete slots. Carefully remove by pulling the wire mesh towards you.

It is essential that the SuperTweeter™ diaphragm is not touched, as damage will destroy its performance and require specialist repair by your Tannoy dealer.

Any such damage will not be covered under warranty.

BASS DRIVER

To deliver accurate and extended low frequencies, the Kingdom Royal features a 15in multi-fibre bass driver with massive ferrite motor system and underhung voice coil. In an underhung configuration the top plate is extended to ensure the voice-coil remains completely within the flux of the magnet over its entire range of motion.

While underhung driver topology is expensive to implement, the result is constant electromotive force on the voice coil leading to significantly lower distortion than traditional driver designs and improved motor cooling. Extensively tuned by Tannoy's most experienced electro-acoustic engineers, the bass driver produces prodigious low frequency extension with fluid and articulate bass delivery through to the crossover point with the DC driver. The cabinet has been engineered to offer ideal damping and suspension characteristics while the rear port is tuned to an extremely low 15Hz in order to retain the Kingdom Royal's ultra-fast dynamics into the sub-bass range.





CROSSOVER

The Kingdom Royal necessitated the most sophisticated crossover Tannoy has ever designed, splitting the low frequency and high frequency sections into individual assemblies, to avoid any electrical interaction between the two. The entire crossover is decoupled from the cabinet base using an innovative free-floating isolation system, with rubber suspension turrets. Both upper and lower HF and LF boards are hard-wired (i.e. not a printed circuit board) using silverloaded solder and six nines PCOCC™ copper (99.9999% pure copper) cable.

After extensive testing 99.997% purity single strand silver cable was chosen for the SuperTweeter™ circuit for its exceptional top end transparency. Tannoy's DMT™ (Differential Materials Technology) compound is used to seat components, further improving damping and resulting in greater naturalness and pin point imaging. Once assembled the entire crossover undergoes full deep cryogenic treatment to relieve component and conductor stresses at crystal level. While cryogenic treatment is a costly process for such a large assembly, the resulting benefit in terms of musical cohesion and smoothness make it an essential part of the Kingdom Royal's natural sound.

At crossover component level, the component choice to match the new Kingdom Royal drivers was a critical design concern. Many brands and types of component were auditioned and rejected before the final configuration. Each crossover uses the very latest ICW ClarityCap™ MR polypropylene capacitors as these were found to have the lowest internal resonance and better self damping than any other capacitor on the market. Low loss laminated core inductors are used throughout and non-inductive heat-sink mounted thick film resistors were chosen for their micro-dynamic capabilities and thermal stability.

Impedance matching the Dual Concentric™ HF unit was another area of concern, with the very best acoustic results coming from a custom-built autotransformer rather than traditional resistive circuit, in order to maintain damping. Adjustments for the Dual Concentric™ Tweeter and SuperTweeter™ energy levels are available using a new low-loss switching panel mounted on the front baffle.

On the rear panel very high quality WBT™ binding posts are configured in Tannoy's unique five-terminal arrangement that affords bi-wiring and bi-amping as well as direct grounding (via the fifth terminal) for the chassis of the main drivers. The grounding of the chassis helps to reduce radio frequency interference providing a smoother sound with improvements in detail and transparency.

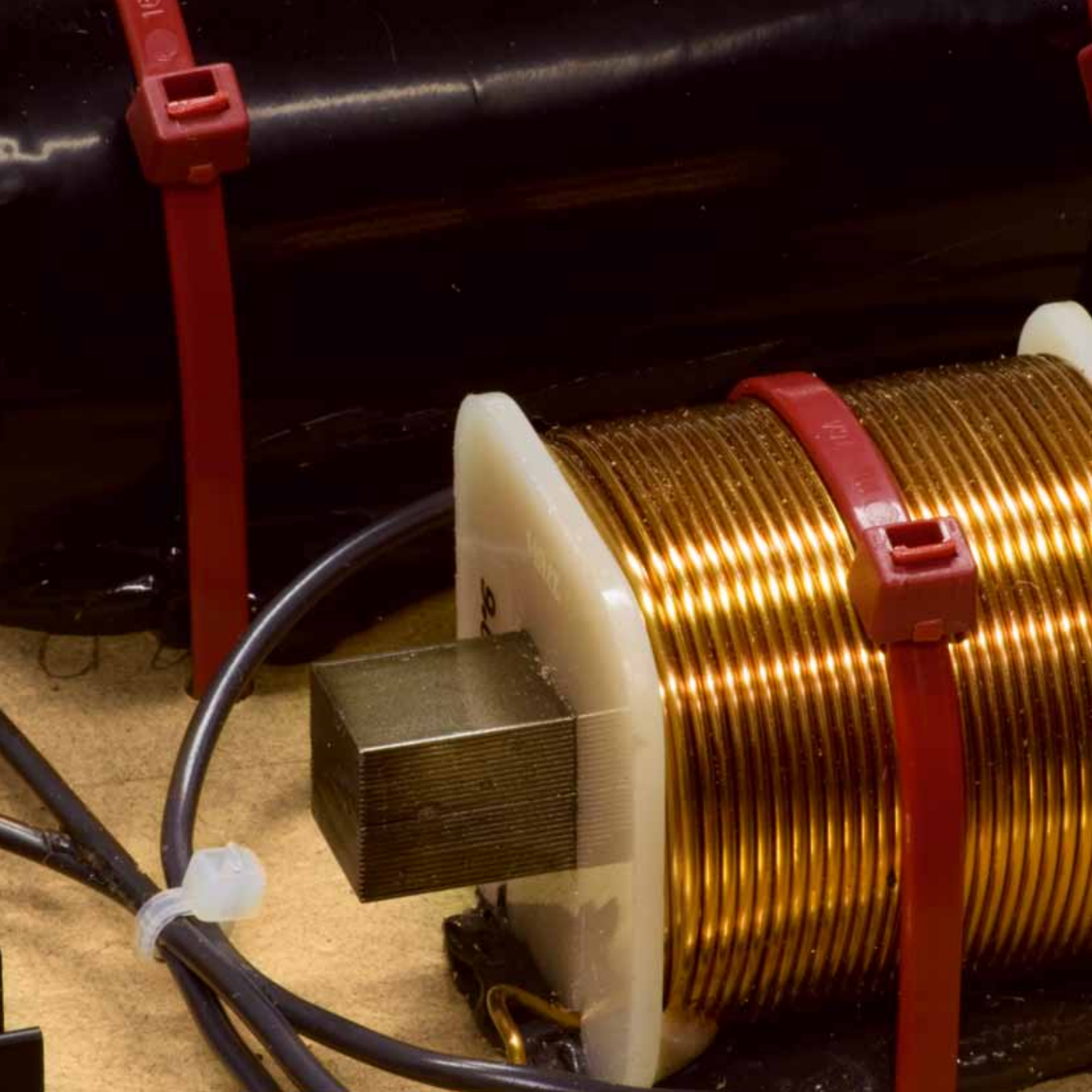

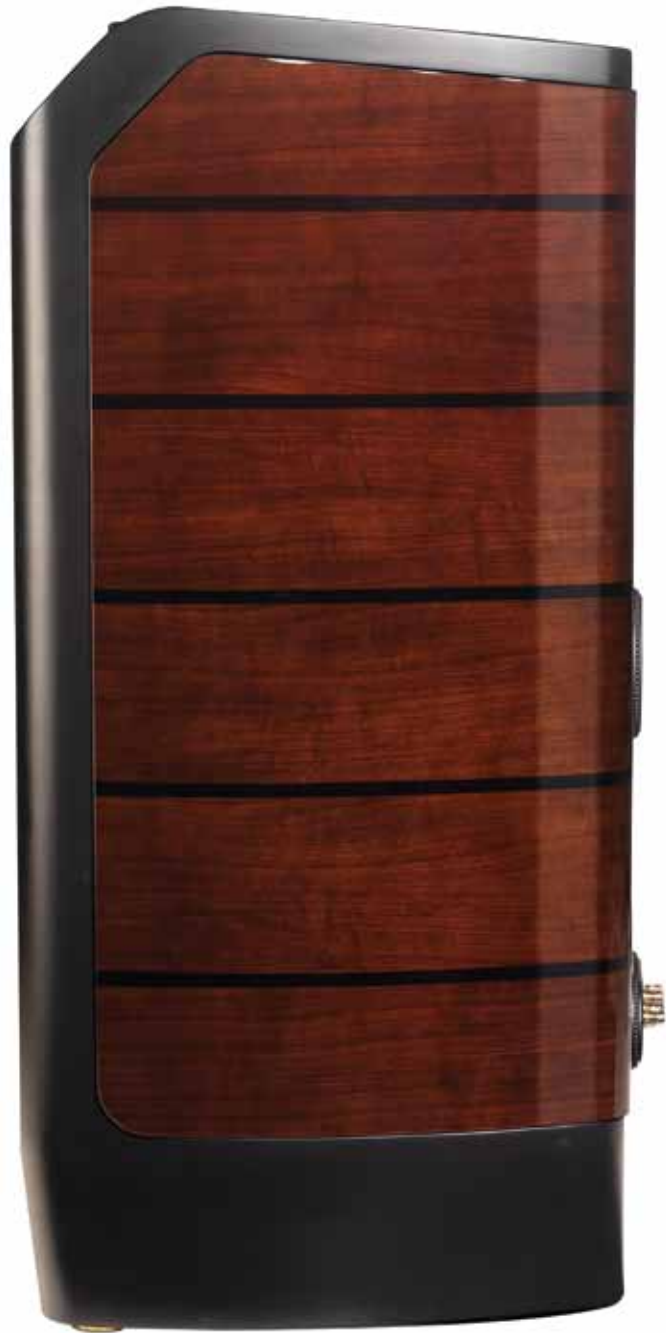

ENCLOSURE

The Kingdom Royal cabinet derives its striking visual form from its no compromise function. The massive curve-sided cabinet is constructed from machined high density fibreboard laminated with birch plywood sourced from cooler, slow growing regions of the world for its superior density and acoustic properties. Built with both vertically and horizontally laminated panels and braced with Tannoy's DMT™ technology, the cabinet is incredibly rigid despite the large panel areas.

This engineering technique has afforded a very stiff enclosure with high internal volume that allows the deepest bass notes to be accurately reproduced.

The sealed SuperTweeter™ enclosure is precision milled from a laminate of medium density fibreboard and acoustically separated from the main cabinet enclosure. Tuned and damped by both measurement and audition, its performance is further enhanced by a soft dispersion panel set in front of the housing. After trialling a number of synthetic and natural materials, soft Italian leather was selected as being the most effective.

UNPACKING

CAUTION:

Each Kingdom Royal loudspeaker is very heavy, weighing 120kg (265lbs). Do not attempt to unpack single handed. We recommend that five people are present to unpack the product for safety reasons. Examine all pieces of packing material and inspect the carton for signs of external damage. If there is evidence of excessive damage to the packaging and resulting damage

to the loudspeaker please inform the carrier and the supplier immediately. Always keep the packaging in such circumstances for subsequent examination. Tannoy strongly suggests that you store the complete packaging set for possible future use.



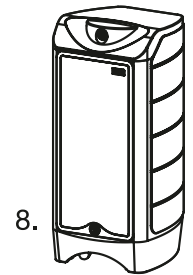
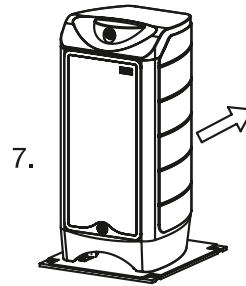
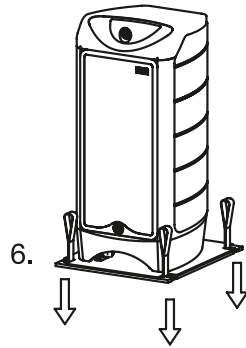
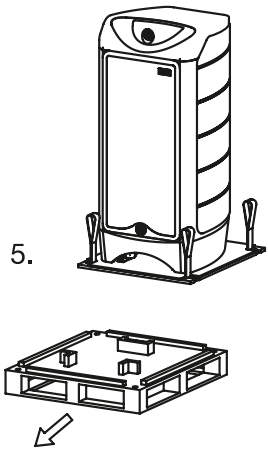
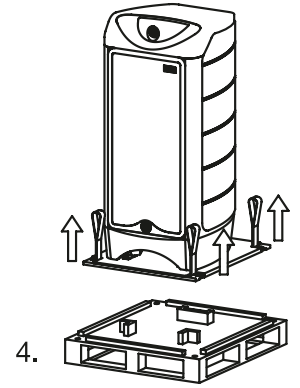
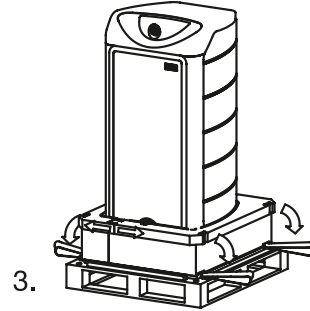
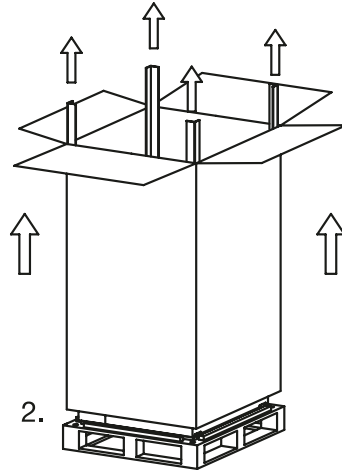
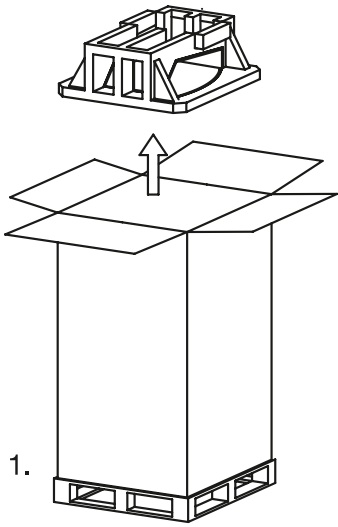

To avoid damage to the finely crafted cabinet, please adhere to the following method:

1. Open the carton top and remove the accessory box and foam cap.
Please note that there is only one accessory box supplied with each pair of loudspeakers.
2. Remove the 4 pieces of edge guard then lift off the cardboard packaging.
3. Pull the straps clear of the bottom foam cap. Split the foam in the position shown and unwrap from product. Do not pull the foam up over the product as this risks scratching the cabinet.
4. Using four people, lift the product using the straps provided.

5. The fifth person should pull the pallet out from under the cabinet.
6. The cabinet can then be placed slowly back on the ground.
7. Gently manoeuvre the product off the rear of the lifting board. As the back edge of the cabinet is on the floor, tip the product slightly on its back edge and pull the lifting board clear to avoid damage to the bottom of the cabinet.
8. Position cabinet at roughly the intended listening position. The attached castors will help considerably with this.

To repack, please follow these instructions in reverse order.

IMPORTANT: It is the responsibility of those involved to safely unpack the product, and Tannoy will not be held liable for any resulting loss, damage or injury.

POSITIONING

Place the loudspeakers with their rear panels approximately 1m from the rear wall. Remember that the proximity of the loudspeakers to walls and corners will affect the sound. Some experimentation will probably be needed to fine tune the stereo image depth and low frequency sound quality. Stereo image separation and depth will be improved by toeing-in the cabinets towards the listening position. The axes of the cabinets can even intersect at a point slightly in front of the listening position. Close-to-wall positions and room corners more so, have the effect of increasing very low frequency sound energy. Reflective adjacent walls may upset the stereo image by causing unwanted reflections.

When the optimum position for the loudspeakers has been determined, position the three metal cups provided in the accessories pack, so that they sit under the three support cones, on the underside of the loudspeaker. These are positioned two at the front and one at the rear. This will give maximum stability, and enable your loudspeakers to provide their full dynamics and resolution of detail.

WARNING: This operation should be carried out by two people, to avoid the risk of personal injury, should the speaker slip or fall.

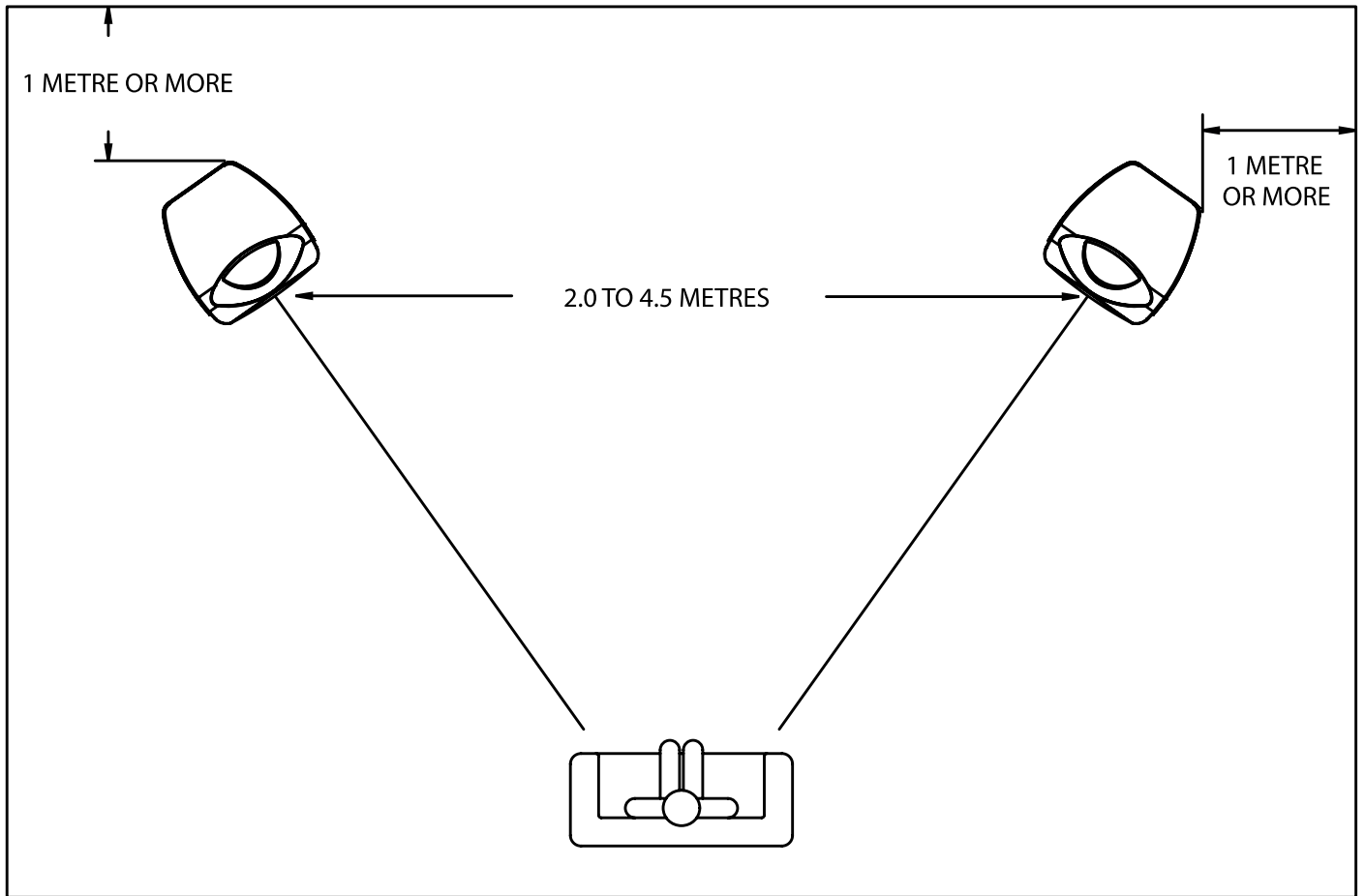



AMPLIFIER CHOICE

Consult the product specification pages within this manual as this clearly shows the acceptable power range for amplifier matching to your speakers. The high peak power handling of Tannoy loudspeakers permits responsible use with more powerful amplifiers - please read the Warranty.

As with all loudspeaker systems, the power handling is a function of voice coil thermal capacity. Care should be taken to avoid overdriving any amplifier, as this will cause output overload resulting in 'clipping' or distortion within the output signal. This may cause damage to the speakers over an extended period.

Generally an amplifier of higher power that is running hard, but free of distortion, is safer than a lower power amplifier continually clipping. Remember also that a high powered amplifier running at less than 90% of output power generally sounds a great deal better than a lower powered example struggling to achieve 100%. An amplifier with insufficient drive capability will not allow the full performance of the loudspeakers to be realised.

Some customers however may wish to use low powered valve (tube) amplifiers, such as single ended triode designs, with outputs lower than our recommended minimum amplifier power. The use of such amplifiers will not cause damage to the loudspeaker, but dynamic range and maximum volume will be limited, especially in larger rooms.

CABLE CHOICE

Always use the best quality of cable available within your budget. High quality audio signals passing from the amplifier to the loudspeaker are unusual in their demands on the cable. Wide dynamic range and frequency bandwidth information has to coexist with the ability to transmit peak currents of at least 10 amps, without incurring any loss or signal impairment. This is why the sound quality of the information reproduced by the loudspeakers is so dependent on the physical properties of the cables connecting them to the amplifier.

We would recommend that you always keep the cable runs the same length for each speaker. Remember that cable construction can affect the sound quality so be prepared to experiment to find a cable that suits your listening preference and audio system.



fig. 1

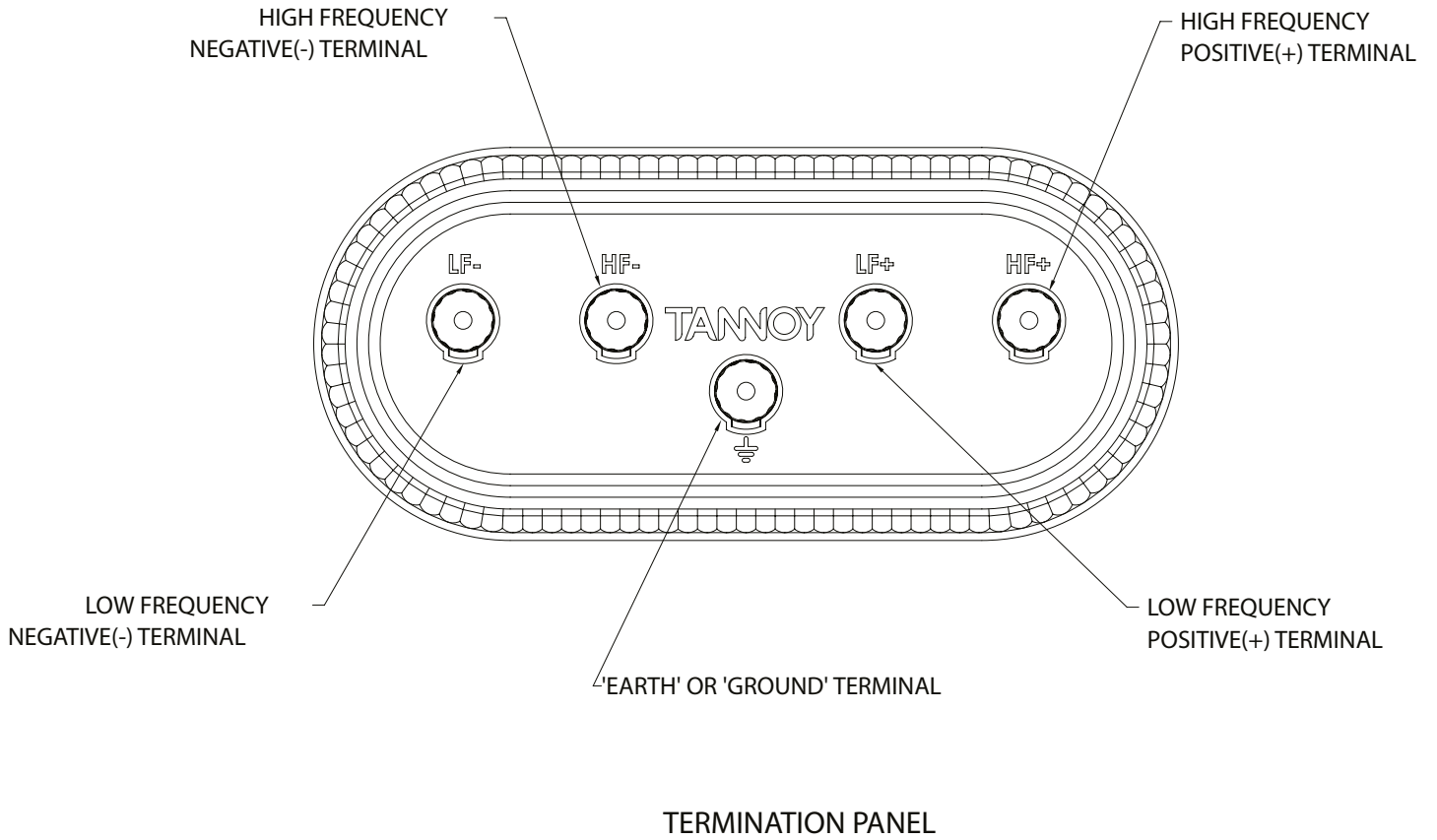

AMPLIFIER CONNECTIONS

Referring to the terminal panel diagram **(see fig. 1)**, both low and high frequency sections of the loudspeaker are provided with their own set of input terminals. This enables operation in either single wire, bi-wire or bi-amp configuration. For optimum performance, the earth connection on the terminal panel should be connected to the amplifier chassis earth or other ground point. This screening effect can give an improvement in detail clarity, depending on the amplifier used. Optimum results are achieved using a screened loudspeaker cable designed for such a system.

SINGLE WIRE CONNECTIONS

Connect the loudspeakers to the amplifier using a high quality cable. Your dealer will be able to make recommendations. The terminals will accept either spade or banana plugs. Fit the link wires from the accessories box, **(see fig. 2)**.

Arrange the connections so that the right hand amplifier channel terminals are connected to the right hand loudspeaker as viewed from the listening position.

Correct polarity of the connections between the amplifier and speakers is essential. The positive terminal on the amplifier left channel, marked + (plus) or coloured red, must be connected to the positive terminal on the left loudspeaker. The negative terminal on the amplifier left channel, marked - (minus) or coloured black, must be connected to the negative terminal on the left loudspeaker.

Repeat this connection for the right speaker. Good quality cables and tight, well-made connections are necessary to eliminate resistive losses and maintain the correct damping of the loudspeaker by the amplifier.

fig. 2

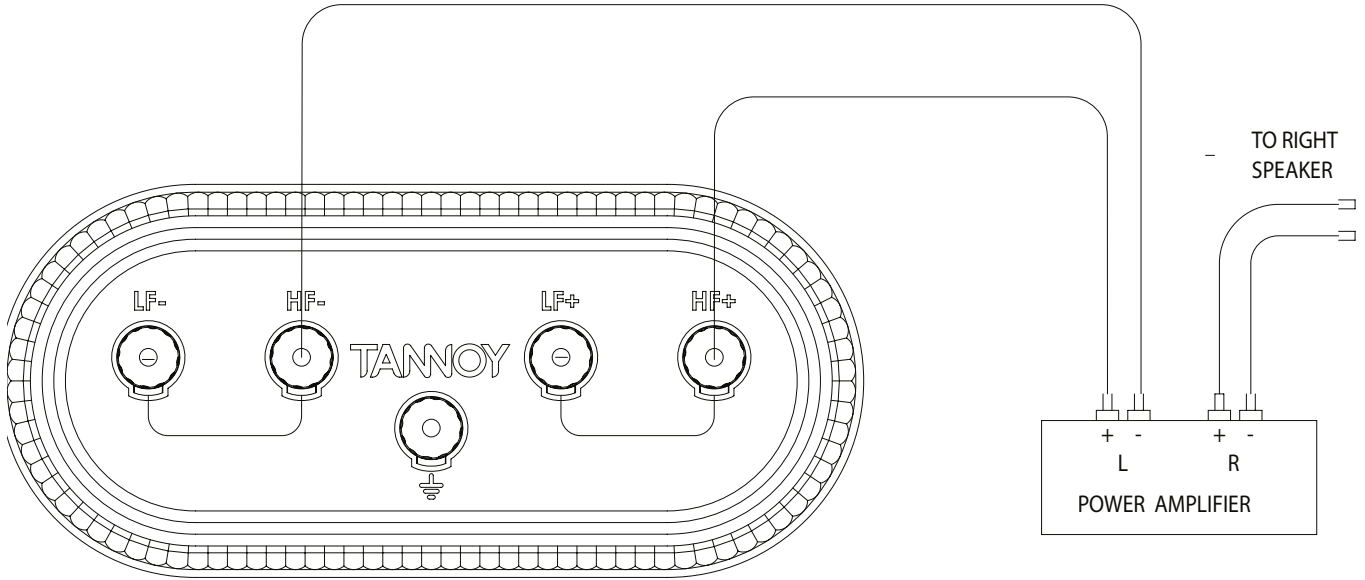

LINK WIRES IN PLACE

SINGLE WIRE CONNECTION



If the cables and connections have been made correctly as described above the loudspeakers will be automatically in phase with each other. However if phasing is felt to be incorrect (for example, diffuse stereo image, lack of bass) then apply the following test:

Place the loudspeakers side by side and play a monophonic signal from the amplifier, choosing the programme material with a strong bass content. If phasing is correct bass will be full and rich. If incorrect there will be very little bass due to cancellation effects. Incorrect phasing can be remedied by reversing the connecting leads to one loudspeaker (at either the amplifier or the loudspeaker terminals but not both).

Note: Be certain to ensure that the amplifier is switched off when connecting or disconnecting loudspeaker leads. Also accidentally shorting the loudspeaker leads together can damage some amplifiers. Such damage is outside warranty provisions.

BI-WIRING THEORY

Loudspeakers need power signals to produce acoustic energy when reproducing music. The range of electrical currents passing down the cable from the amplifier to the loudspeaker is very wide. In decibel terms this is called the dynamic range. Modern loudspeakers are capable of resolving a very wide dynamic range with a suitable power amplifier and programme source. This dynamic range of over 80dB can correspond to voltages of between 50 Volt and 0.005 Volt at the loudspeaker terminals or equivalent currents of between 0.0006 and 6 Amp. This is a truly wide range of electrical signals to pass down one cable without some interactions causing a loss of resolution in the very small signals.

When electricity passes down a wire or cable, what goes in at one end is unfortunately different from what comes out at the other. The degree of loss or modification of a signal depends on the physical characteristics of the cable and the nature of the signal. Heavy electrical currents flowing down thin conductors cause heating effects. Very high frequency signals passing along conductors or cables of certain lengths cause electromagnetic radiation effects (aerials). Electrical cables are selected for minimum loss and maximum information resolution considering the type of electrical signals they are designed to carry.

A good solution to the problem is to 'bi-wire' the loudspeakers to the amplifier. This means providing two separate sets of cables from the power amplifier to each loudspeaker and dividing the electrical signals into high current, 'slow' signals and light current, 'fast' signals. Of course, the loudspeaker must be fitted with two pairs of terminals to take the two sets of cables; your Tannoy loudspeakers are of course equipped for just this type of connection.



WBT 0645

WBT 0645

11/8

fig. 3

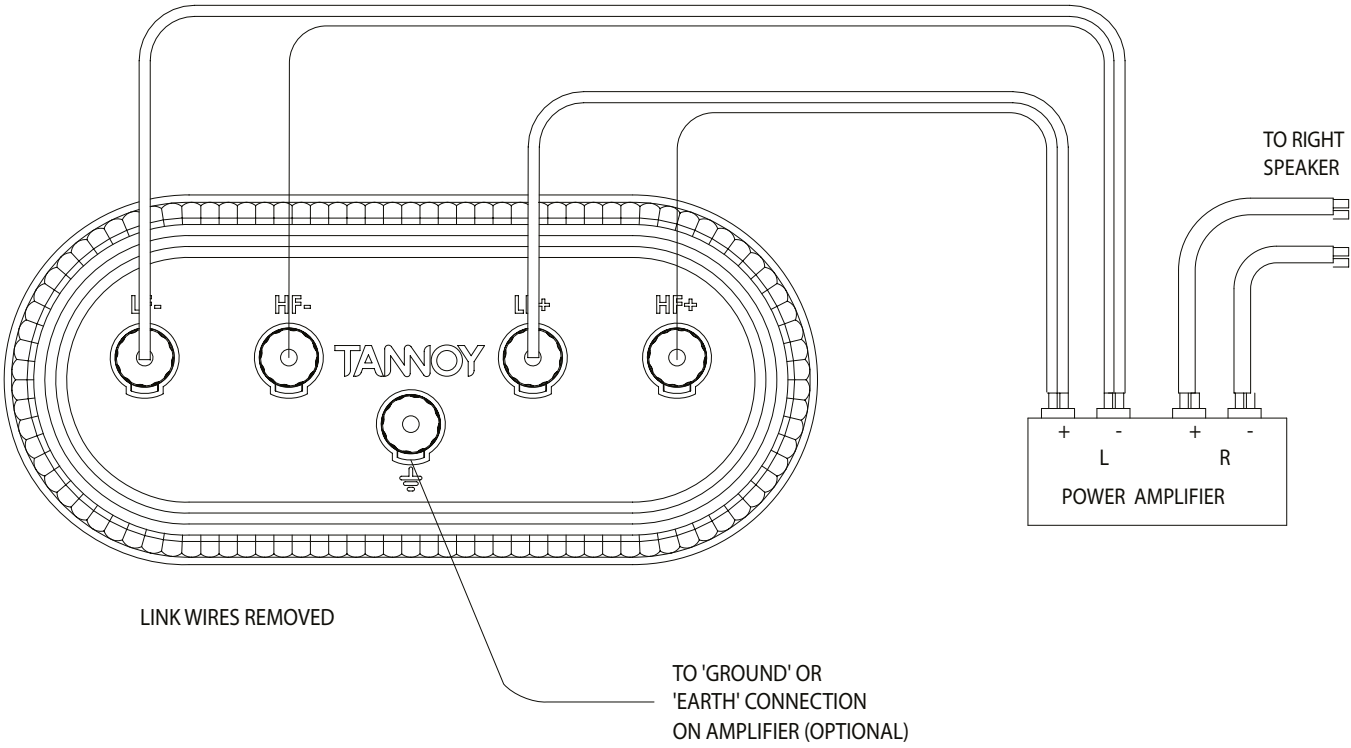

BI-WIRING CONNECTIONS

Bi-wiring releases the full potential of the Tannoy Kingdom Royal loudspeakers. Two complete sets of cable are required. Switch the amplifier off. Deal with each 'side' of the system separately. Label two of the cables Left LF and Left HF (low frequency and high frequency), referring to the diagram

(see fig. 3).

Do the same for the right pair. Undo the loudspeaker terminals, remove and retain the Bi-wiring links so that the same polarity terminals are no longer joined.

It is essential to get the polarity correct. If your amplifier does not have separate output terminals for bass and treble then, at the amplifier end of the cable, connect the Left LF+ and HF+ cables together. Then wire to the amplifier Left channel positive terminal marked + (plus) or coloured red.

Connect the Left LF- and HF- cables together to the amplifier negative terminal marked - (minus) or black.

Note the polarity marking on the cable. At the loudspeaker end connect the cables marked Left LF+ and LF- to the appropriate left speaker LF terminals. Connect the Left HF+ and HF- to the appropriate + and - left speaker HF terminals.

Make the same connections with the Right LF and HF cables. Note the polarity of the cable and be sure to connect + to + and - to -, the LF cables to LF terminals and HF to HF.

Switch on the amplifier with the volume turned down. Select a favourite source and carefully turn up the volume. Check that bass and treble sounds come from both speakers. If not, switch off and recheck the connections.

Bi-amping extends the principle of bi-wiring one stage further. In this connection option separate power amplifiers are used for bass and treble signals in each loudspeaker. Four mono (or two stereo) amplifiers of the same type are required for a stereo pair of loudspeakers. Ensure that the cable links between the loudspeaker terminals are removed and that correct polarity is maintained throughout.

If two stereo amplifiers are used, it is recommended that one amplifier supply bass information to left and right loudspeakers and the other, the treble information, referring to the diagram **(see fig. 4)**.

fig. 4

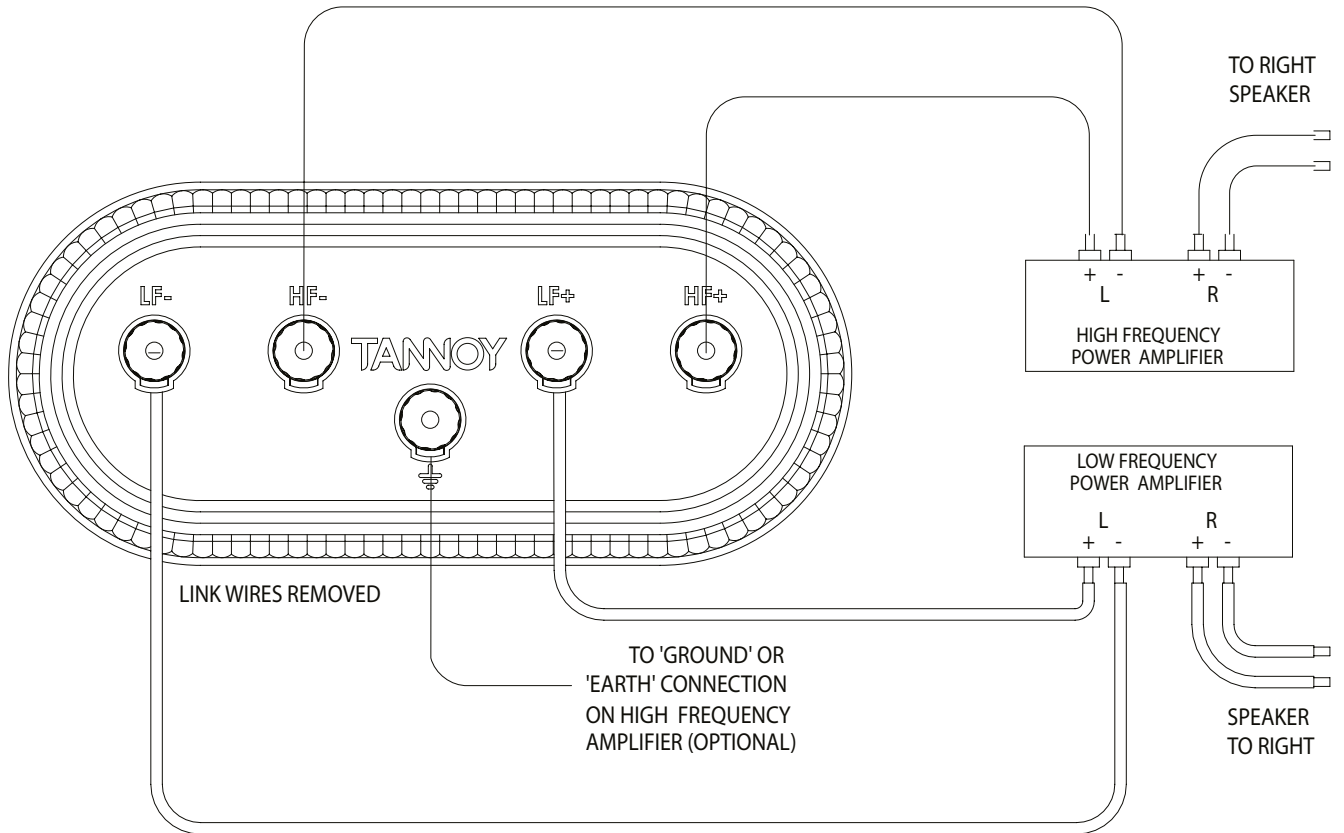



GRILLE REMOVAL

Special acoustically transparent cloth is used in the grilles. However, for ultimate fidelity the enthusiast will find it is best to use these loudspeakers with their grilles removed during listening.

The grilles are held in place by invisible magnetic catches. To detach the grille, gently pull the removal knob outwards, and carefully lower the grille to the ground.

LOUDSPEAKER SYSTEM ADJUSTMENT

Each loudspeaker is fitted with two controls located on the front baffle beneath the grille. These high current switch blocks are labelled DUAL CONCENTRIC HF ENERGY and SUPERTWEETER ENERGY. They can be used to compensate for the varied acoustic characteristics of listening rooms. The loudspeaker has been designed to sound neutral with these controls in the 0dB or middle positions. The controls should be adjusted with any amplifier tone controls in the 'flat' or uncompensated position.

The ENERGY controls have five positions. They allow the output of the Dual HF compression drive unit and SuperTweeter™ to be increased or decreased from the linear or 'flat' position in 1.5dB steps, as indicated below.

The adjustment frequency range for the Dual HF is between 700Hz and 17kHz, while the SuperTweeter™ adjustment range is from 17kHz upwards.





DUAL CONCENTRIC HF ENERGY

-3.0

-1.5

0

+1.5

+3.0 dB

TAI



RUNNING IN

Like all loudspeakers, the drive units in your Kingdom Royals require a while to reach optimum performance, as the stresses in the materials relax - especially in the suspension systems.

For this reason, it is beneficial to run the system at fairly high levels at normal room temperature, for approximately 20 hours to achieve best results, although further improvements will be heard over a more extended time.

A NOTE ON AUDITORY PERCEPTION

Our hearing mechanism locates natural sound sources with great accuracy by using the naturally occurring phase differences (or arrival times) at middle frequencies, and intensity differences at higher frequencies, between each of our ears. Naturally occurring sounds pass through the air to the ears at constant speed (345 metres/second or 1132 feet/second). All frequencies travel at the same speed and therefore a frequency independent time delay is associated with the distances involved. (The familiar time delay between a flash of lightning and the associated clap of thunder is an example).

Human hearing relies on the constant nature of the time delay with the intensity to locate natural sounds accurately. These Kingdom Royal loudspeakers can uniquely reconstruct stereo images and provide excellent localisation of recorded sounds.

The Tannoy Dual Concentric™ principle ensures that the source of sound at high frequencies is on the same axis as the source of sound at low frequencies.

The careful design of crossover network complements the drive unit to provide a coincident sound source at frequencies where the human ear derives phase information for localisation. The loudspeaker system exhibits a time delay response that is in essence independent of reproduced frequencies. In addition, the amplitude (or intensity) response is linear, smooth and consistent. This provides the correct intensity information to recreate the original sound stage.





CARE OF CABINET

The cabinet may be cleaned with the Microfibre cloth provided in the accessories pack. The high gloss wooden sections may be occasionally cleaned with a high quality non-silicone furniture polish.

On no account use any solvents or any abrasive materials.

FAULT FINDING

Tannoy loudspeakers are designed and manufactured to be reliable. When a fault occurs in a hi-fi system the effect is always heard through the loudspeakers although they may not be the source of the fault. It is important to trace the cause of the problem as accurately as possible.

A fault heard on one source (only CD or tape for instance) is most unlikely to be a loudspeaker problem. Loudspeakers do not generate hum, hiss or rumble although high-quality, wide-bandwidth loudspeakers may emphasise such problems.



TANNOY

KINGDOM
ROYAL

WARRANTY

No maintenance of the Kingdom Royal loudspeaker is necessary. Please register your Tannoy product online at www.tannoy.com.

All of our products have been produced and tested with care and precision to give first-class service.

All passive components are guaranteed for a period of five years from the date of purchase from an authorized Tannoy dealer. All active and electronic components are guaranteed for a period of two years from the date of purchase from an authorized Tannoy dealer. Misuse, overload, or accidental damage to Tannoy passive or active and electronic components are not covered by this warranty.

If at any time during this warranty period the equipment proves to be defective for any reason other than accident, misuse, neglect, unauthorised modification or fair wear and tear, we will repair any such manufacturing defect or, at our option, replace it without charge for labour, parts or return carriage.

If you suspect a problem with a Tannoy product then, in the first instance, discuss it with your Tannoy dealer. If you require further assistance then we ask that you deal directly with your local Tannoy distributor. If you cannot locate your distributor please contact Customer Services, Tannoy Ltd at the address given below.

Customer Services, Tannoy Ltd.,
Rosehall Industrial Estate, Coatbridge,
Strathclyde ML5 4TF, Scotland

Telephone: 01236 420199 (National)
+44 1236 420199 (International)
Fax: 01236 428230 (National)
+44 1236 428230 (International)
E-mail: enquiries@tannoy.com

Do not ship any product to Tannoy without previous authorisation.

Our policy commits us to incorporating improvements to our products through continuous research and development. Please confirm current specifications for critical applications with your supplier.

TECHNICAL SPECIFICATIONS

Cabinet Dimensions (H x W x D)	1275 x 585 x 600 mm (50.2 x 23.0 x 23.6")
Enclosure Volume	160 litre (5.65 cu.ft.)
Enclosure Type	Reflex for bass driver, closed box for Dual Concentric™
Enclosure Weight	120kg (265lbs)
Recommended Amplifier Power	20 to 600 watt RMS per channel
Power Rating	300 watt RMS 1200 watt peak
Maximum SPL	120dB at 1 metre for 300 watt RMS 126dB at 1 metre for 1200 watt peak
Total Harmonic Distortion	Less than 1% at 300 watt RMS (50Hz to 20kHz)
Sensitivity	96dB for 2.83 volt at 1 metre
Nominal Impedance	8 Ohms
Dispersion	90 degree conical
Frequency Response	24Hz - 61kHz (-6dB)
Crossover Frequencies	120Hz bass to Dual Concentric™ midrange 700Hz Dual Concentric™ midrange to compression tweeter 17 kHz Dual Concentric™ tweeter to SuperTweeter™
Crossover Adjustments	Dual Concentric™ energy +/- 3.0dB in 5 steps, 700Hz- 17kHz SuperTweeter™ energy +/- 3.0dB in 5 steps, 17kHz- 61kHz
Crossover Type	Bi-Wired, Hard-Wired passive, low loss. All connections silver soldered. 99.9999% purity PCOCC™ wiring, except for SuperTweeter™ 99.997% purity single strand custom silver cable. Complete assembly deep cryogenically treated. Free floating isolation system. All crossover slopes 2nd order, except for SuperTweeter™ 1st order high pass
Low Frequency Driver	305mm (15 inch) nominal diameter with treated paper cone. 75mm (3 inch) diameter voice coil
Dual Concentric Driver	300mm (12 inch) nominal diameter Dual Concentric™, with 52mm (2 inch) midrange voice coil and treated paper cone. High frequency 75mm (3 inch) diameter aluminium alloy dome, deep cryogenically treated
Supertweeter™	25mm (1 inch) diameter 64 micron magnesium alloy dome, ceramic coated. Neodymium magnet system. Plasma bonded voice coil
Cabinet Construction	Birch ply and high density fibreboard. Extensive internal bracing



A statement in engineering excellence

t a n n o y . c o m

Tannoy United Kingdom
Tannoy Deutschland
Tannoy Middle East
TC|Group International
TC|Group Americas

T: 00 44 (0) 1236 420199
T: 00 49 (180) 1111 881
T: 00 971 (04) 4401208
T: 00 45 8742 7000
T: 00 1 (519) 745 1158

E: enquiries@tannoy.com
E: anfragen@tannoy.com
E: enquiries@tannoy.com
E: info@tcgroup-international.com
E: info@tcgroup-americas.com

Tannoy adopts a policy of continuous improvement and product specification is subject to change.